

ProScrub

Wet Type Dust Collector

Applications

- Dry/wet finishing
- Deburring Operations
- Media Blasting
- Non-NFPA Combustible Metal Finishing Operations
- Metal Finishing
- Food Processing
- Pharmaceutical Processes
- Biomedical Manufacturing
- Shot Peening
- Sand Blasting

**Now Standard
Stainless Steel
Construction
with
Interior & Exterior
Tank Coatings!**



Industrial Ventilation Professionals
Dust & Oil Mist Collection Equipment For Industry

staff@proventilation.com

800-610-6010

www.proventilation.com



ProScrub Wet Type Dust Collectors

ProScrub wet type dust collectors are modeled after the well known Uni-Wash wet type collector product line that has been an industry standard for over 75 years. Designed for use in finishing, sanding, grinding, and mixing processes, the ProScrub dust collector provides excellent air cleaning efficiency through an advanced, yet simple water washing action. The patented "scrub" is accomplished using airflow to create a series of water curtains which trap and remove dust particles from the inbound dirty air stream. Clean air passes through a final stage mist filtration pack and exhausts out the top of the unit. Simple, powerful, and compact -- these rugged machines will provide years of low-maintenance and dependable performance!

Standard Features include a large removable lexan view port and bolted cover plate access to the fan section and mist eliminator sections of the machine. A large mechanical float valve monitors water level for consistent operating level accuracy and is easily accessible for cleaning from the side of the machine.

Now with standard stainless steel construction and long wearing interior & exterior coatings.

- **Standard** Stainless Steel or optional Mild Steel Construction
- Automatic Water Level Control
- NEMA 12 Start/Stop Operation
- Optional Ductwork Package
- Stocked for Immediate Delivery

ProScrub Wet Type Dust Collector Specifications				
Model	PS-1200	PS-1800	PS-2500	PS-3000
Width	42.25"	42.25"	42.25"	42.25"
Depth	53.375"	53.375"	53.375"	53.375"
Height	80"	80"	80"	80"
Flanged Inlet	7"	9"	10"	12"
Dry Weight, lbs	700	750	800	850
Volume, CFM	1,200	1,800	2,500	3,000
Static Pressure, wg	4" External	3" External	5" External	4" External
Motor, HP*	3	3	5	5
Electrical	460 Volt/3 Phase/60 Hertz			
Fan	Injection Molding from high strength GRP Polyimide, Corrosion-Proof, Super Quiet, Highly Efficient, Stronger than Steel with half the weight (*requires much lower HP for energy savings)			
Housing	10 gauge and 3/16", Solid Welded, Stainless Steel			
Internal Tank Coating (corrosion protection)	AmerLock-2 by Ameron is a 2-Part Epoxy that provides exceptional corrosion protection in harsh industrial & marine corrosive environments.			
External Coating	Durethane DTM by PPG is a direct-to-metal Urethane Mastic coating that is chemically resistant and extremely durable. It provides excellent corrosion resistance and has superior color and gloss retention, excellent adhesion, UV protection, and is abrasion and mar resistant			
Plumbing	Inlet: 3/4" Schedule 40, NPT Drain: 2" Capped with 2" NPT overflow			
Optional Motor Controls	NEMA 12, Start/Stop with overload protection			
Water Level Control	Heavy Duty, Industrial Brass Float Type			

ProScrub

Wet Type Dust Collector

Standard Features

- Lazer Cut 10 Gauge Stainless Steel Solid Weld Construction
- Durable Interior and Exterior Coatings
- Super-Efficient, Multi-Stage, Wash Process
- Powerful C-Face, Direct Drive TEFC Motor 230/460V/3Ph/60Hz
- Lexan Scrub Action Viewing Window with Water Level Indicator
- High Efficiency Integral Fan Assembly
- NEMA 12 Start/Stop Controls
- Fan Access Panel Door
- Cleanable Mist Eliminator Filtration Pack
- Standard Flanged Inlets, 7", 9", 10", 12" diameter for easy field installation.

Optional Features

- Hopper Tank Section with Legs
- Mild Steel Construction

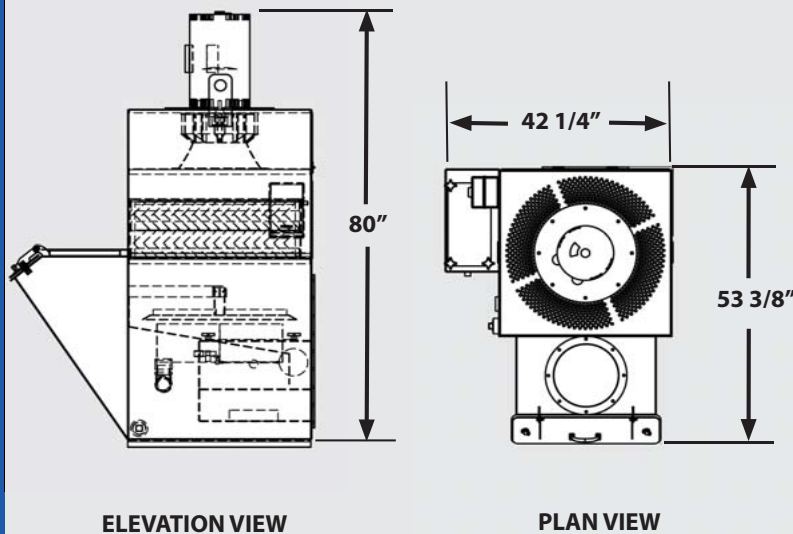
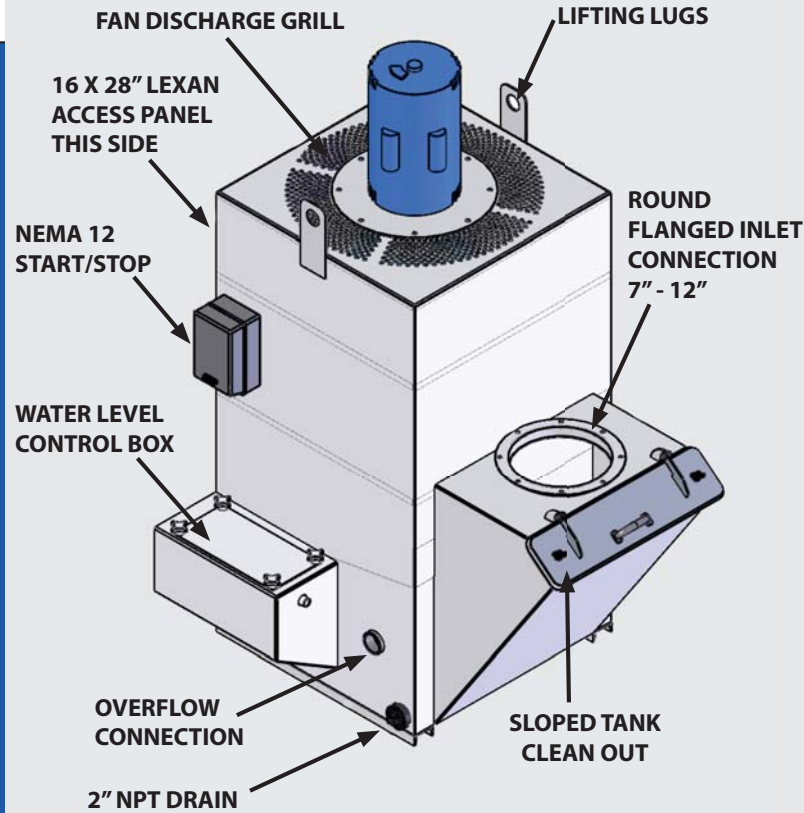

Industrial Ventilation Professionals
Dust & Oil Mist Collection Equipment For Industry

staff@proventilation.com

800-610-6010

www.proventilation.com